

ARTOS

ENGINEERING COMPANY

Machine Model	45-146 Pneumatic Stripper	Owners Manual		
PN	6-119882	Rev. 0	Date	12 Sept. 2006

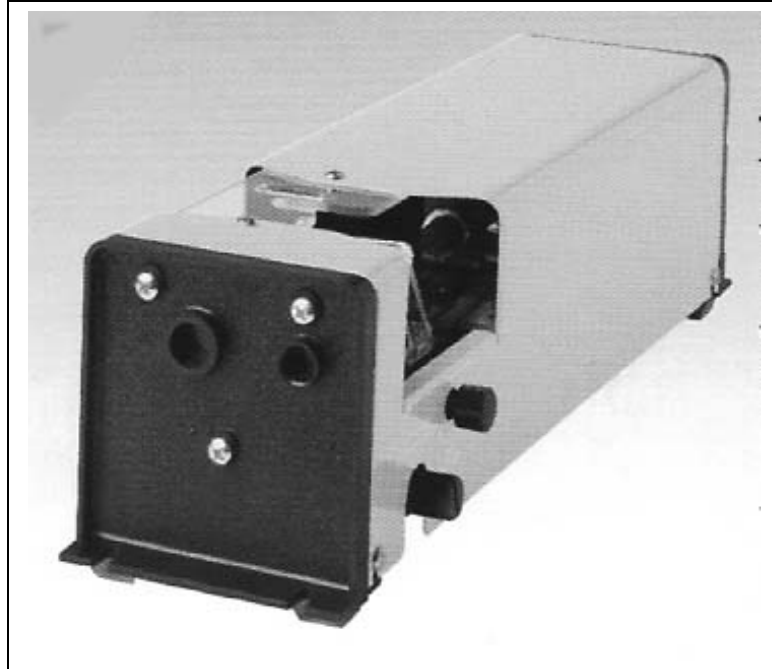

Artos Engineering Company
P.O. Box 1650
Waukesha, WI 53187
Phone 1 262 524 6600 Fax 1 262 524 0400
www.artosnet.com
service@artosnet.com

45-145 & 45-146
Power Stripmaster® Wire Stripper

Owners Manual #6-119882

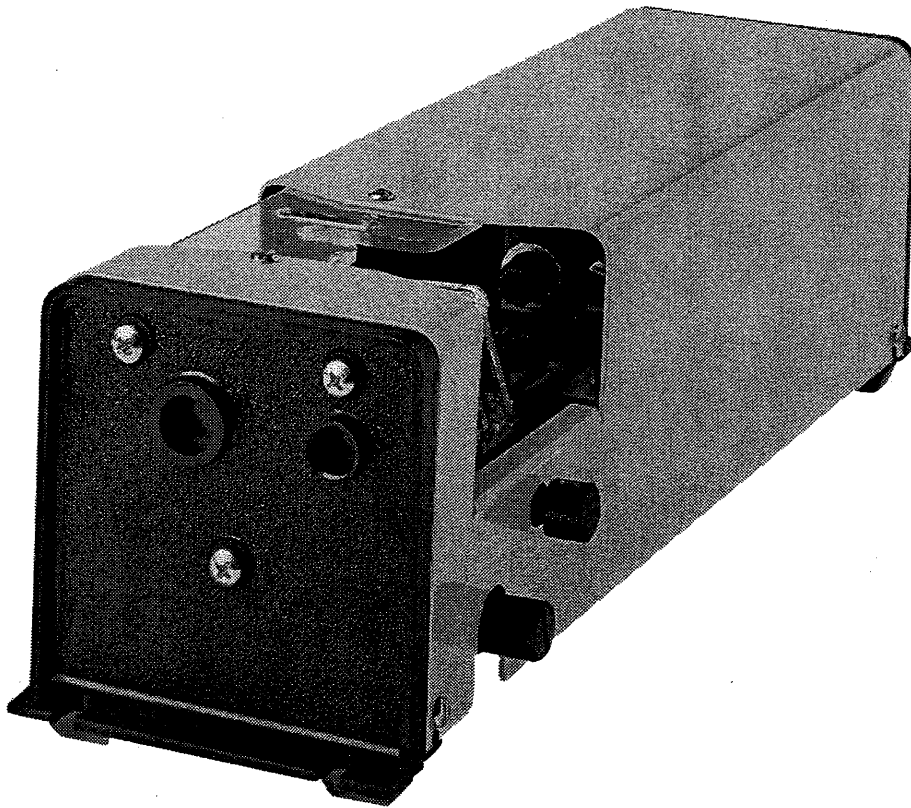

WORLD LEADER IN WIRE PROCESSING SYSTEMS



ARTOS
ENGINEERING COMPANY

PREPARATION FOR USE:

- 1. MOUNTING:** If desired, mount the unit to a bench or other sturdy surface. (NOTE: The Unit Operates Effectively Without Mounting.)
- 2. CONNECT AIR SUPPLY:** Connect the unit to an air line which supplies a lubricated, filtered air source at a maximum pressure of 120 PSI (pounds per square inch) 8.4 BAR. An ON/OFF control must be placed in the air supply circuit between machine and supply source. ARTOS products 45-902 Foot Switch, 45-903 Hook-Up Kit and 45-906 Air Regulator Kit are recommended for the above unit.

NOTE: The unit is supplied with a standard pair of Knife-Type Blades (L-4421) suited for stripping normal commercial wire from 10 to 22AWG. Other blade sets are available for wires outside this range. (See pages 5 and 6.)

It is important to have the gripper assembly aligned properly with the holes in the blade being used. To adjust, loosen the two hexagon head screws and position the plate that contains the gripper assembly as required. Sets in the plate make it possible to traverse it approximately 1/8 (3mm) to either right or left. Tighten screws securely after the assembly is correctly positioned. (See Diagrams A and B.)

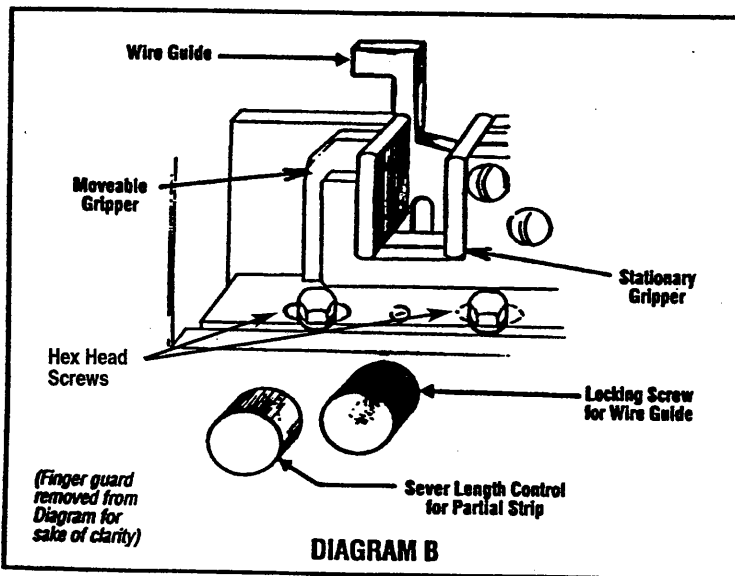
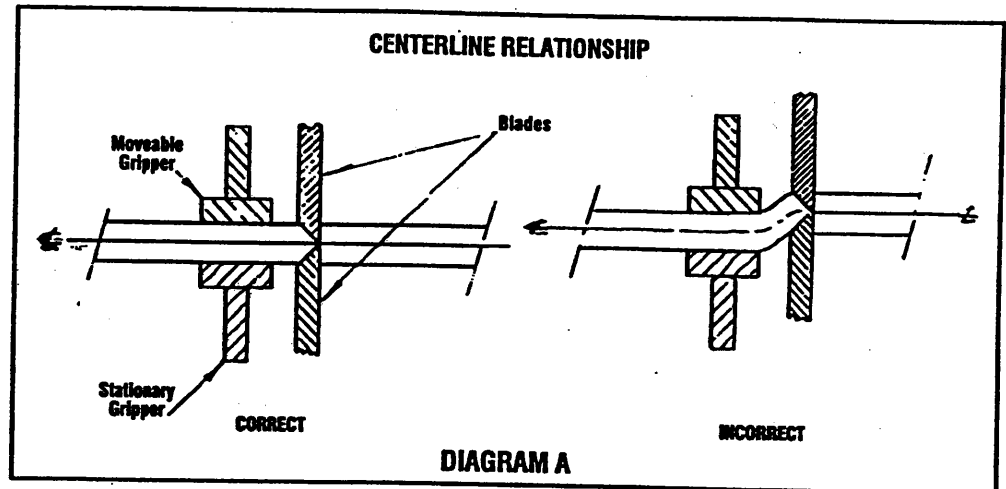

- 3. ADJUST WIRE GUIDE:** Loosen the Locking Screw for Wire Guide and position a sample wire to be stripped in its proper hole location. Position the Wire Guide to a point just beneath the sample wire. Tighten the locking screw. A moderate torque is all that is required. (See Diagram B.)
- 4. ADJUST WIRE STOP:** Loosen screw and move the Wire Stop along the Stop Rod to a position that will give the desired strip length. Tighten screw. (See Diagram C.)
- 5. CHECK POSITION OF SEVER LENGTH (PARTIAL STRIP) CONTROL**

For all normal stripping, the control, located on the front of the unit, should be turned fully counter-clockwise. (See Additional Features Section and Diagram R)

6. NORMAL OPERATION: Place wire to be stripped through the gap between the stripping blades and position the wire against the Wire Stop. The wire should be held in a horizontal position.

Depress Foot Switch to "ON" position. The following actions will occur automatically:

- The gripper will close to hold the wire.
- The stripping blades will close piercing the insulation surrounding the wire.
- The arm assembly will move outward, stripping the insulation slug from the wire.

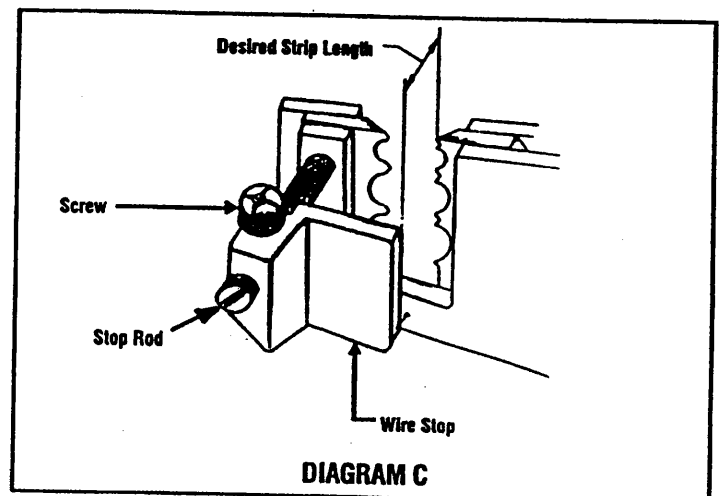

7. Before releasing the Foot Switch, place slight upward tension on the length of wire held by the fingers. Now release the Foot Switch. This tension technique allows removal of the wire before the swinging arm resumes its rest position.

8. **INSULATION (SLUG) REMOVAL MECHANISM:** Removal of the slug (portion of insulation stripped) is accomplished mainly through the inherent mechanical action of the Power Stripmaster Wire Stripper. Under normal stripping conditions, additional aid will not be necessary. However, due to the many and varied types of insulation available, we have provided a wire Slug Ejector for use when circumstances require it. Follow the installation instructions below:

- A. Disconnect air supply.
- B. Remove the outer cover.
- C. Place Slug Ejector in unit. (See Diagram E.)
- D. "Spring load" the ejector. (See Diagram F.)
- E. Tighten screw.
- F. Replace cover.
- G. Reconnect air supply.
- H. Cycle unit several times without wire load.

**NOTE: If after several cycles the Slug Ejector attains a position as shown in Diagram G, loosen screw and repeat steps.*

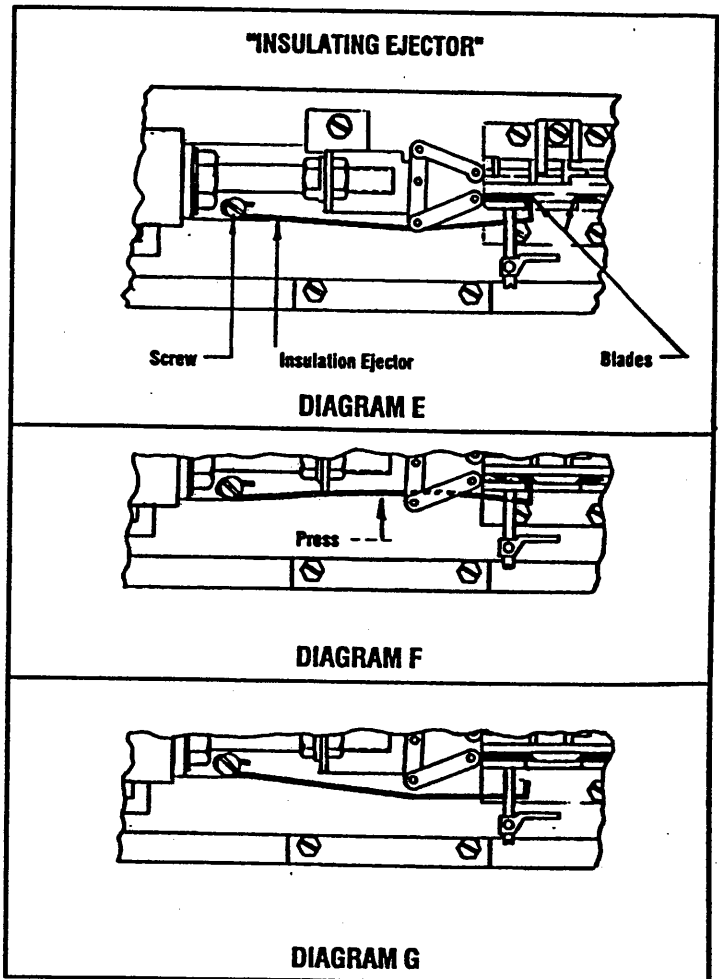

If insulation slugs continue to inhibit production use of the Power Stripmaster® Wire Stripper, the addition of an Accessory Air Blast Slug Ejector will be necessary (ARTOS 45-905). The air blast accessory includes all necessary attires and tubing for connecting it to the Power Stripmaster® Wire Stripper. (See Diagram H.)

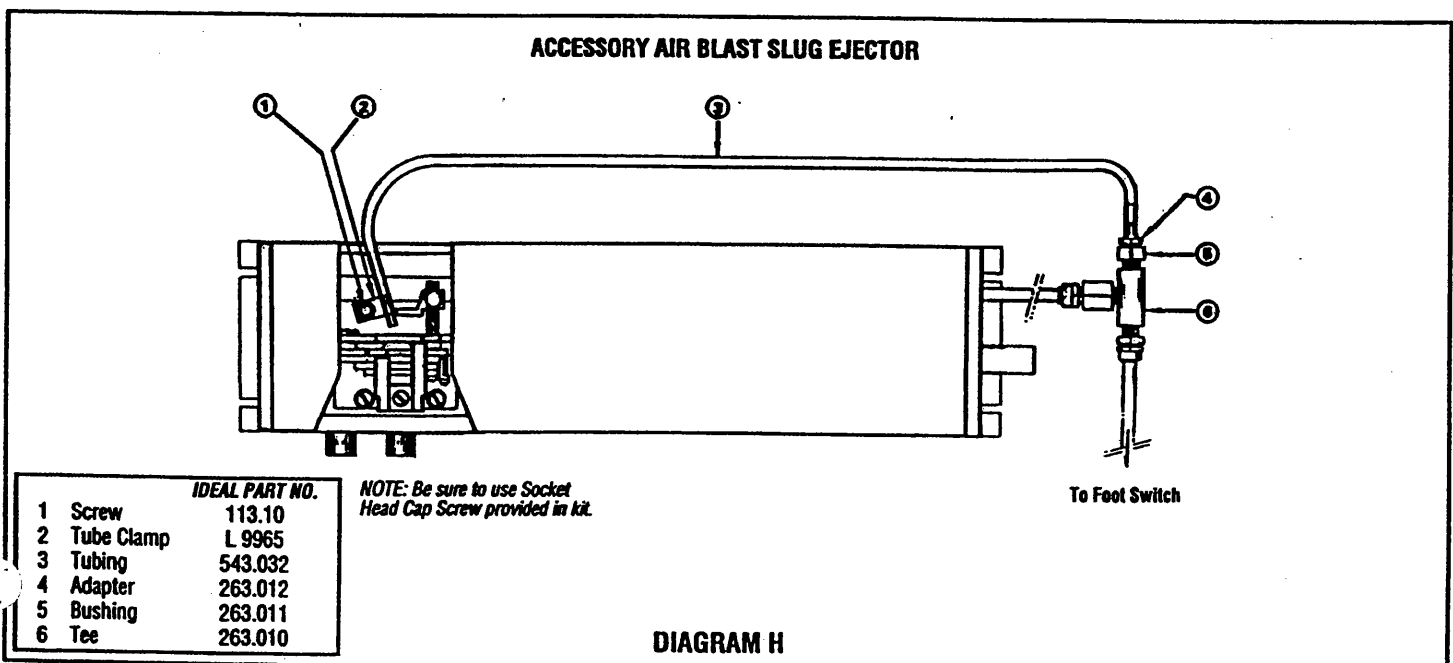

GENERAL NOTE: Air pressure of at least 100 PSI (7 BAR) will be required for stripping tough insulations on larger size wires. Lower pressures will be adequate for normal commercial type wires, Tool life will be increased if the air pressure can be regulated such that the force generated is sufficient to accomplish the required strip without causing excess impact.

FOR BEST RESULTS USE MINIMUM PRESSURE TO ADEQUATELY STRIP WIRE

SAFETY NOTE: Always disconnect the air supply when making any adjustments or repairs to the unit. Do not remove Safety Guards when operating the unit. If a finger were to be caught, the grippers would cause a slight bruising; however, the blades would inflict a severe laceration.

NOISE LEVEL: 75 dbA (79 dbA with air blast)

ADDITIONAL FEATURE:

PARTIAL STRIPPING: A "partial strip" is one which allows the slug to remain on the normally stripped portion of the wire. The advantage of this partial strip is in its allowing postponement of final termination. Loose or frayed ends are virtually eliminated by the slug's "shielding" capability. When termination is to be completed, a pull on the slug will leave the wire stripped and ready to use.

Partial stripping is accomplished by decreasing the stroke of the arm mechanism. Turn the Sever Length Adjustment in a clockwise direction until the slug moves approximately 0.125 in. (3mm). If the Wire Slug Ejector was being used, it must be removed for efficient utilization of the Partial Stripping capability.

MAINTENANCE: Lubricate the sliding parts every 40 hours of operation with SAE No. 10 or equivalent machine oil.

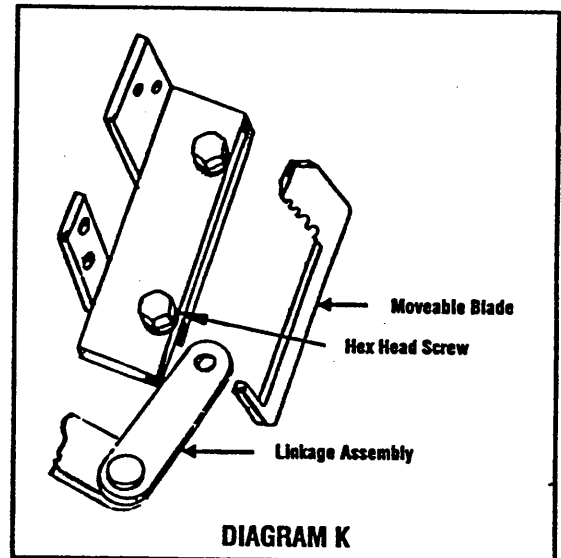
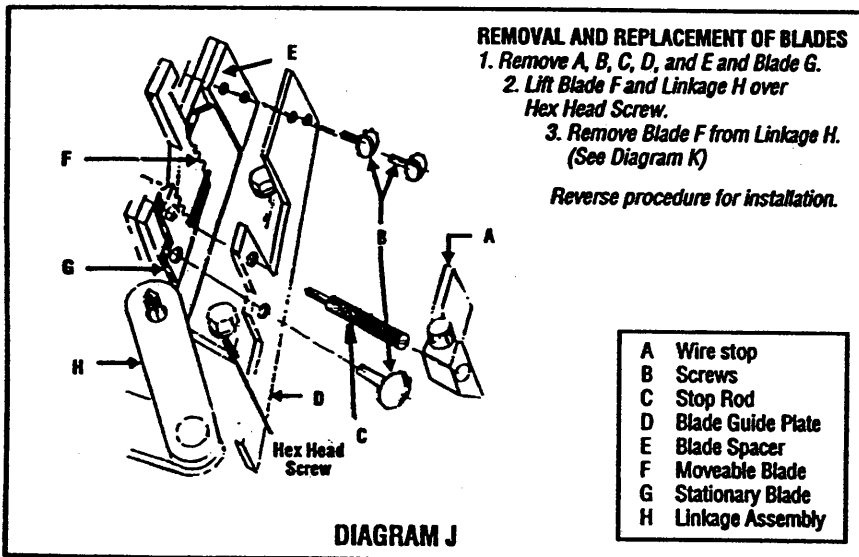

1. TO CHANGE BLADES: (See Diagram J)

- A Disconnect the unit from air supply.
- B Remove Wire Guide Lock by turning counter-clockwise until able to remove from unit.
- C Remove the cover (held in position with four screws).
- D Remove the Wire Stop.
- E Remove Slug Ejector (if attached).
- F Remove the Blade Guide Plate, which is secured by the Stop Rod and three round head screws.
- G The Stationary blade can now be removed.
- H Lift the Moveable Blade and pull it toward the back of the unit. The hook of the Moveable Blade can now be swiveled out from the Linkage Assembly. (See Diagram K.) Fit new blades by reversing the above order, but be sure that the Blade Spacer is secured by the same two round head screws. Fit all screws and the Stop Rod finger tight....do not tighten at this stage!
- I Reconnect air supply and decrease air pressure to approximately 20 PSI (1.3 BAR).

IMPORTANT NOTE: BE CAREFUL TO KEEP FINGERS OUT OF BLADE AREA WHEN OPERATING FOOT SWITCH!

- J Operate Foot Switch holding it in the "ON" position. This action will align the blades. With the Foot Switch held in "ON" position, fully tighten Stop Rod and the three securing screws.
- K Increase air pressure to previous setting.

2. TO CHANGE GRIPPERS: (See Diagram L)

- A Remove Finger Guard.
- B. Remove round head screws.
- C. Remove Stationary Gripper.
- D. Lift Movable Gripper and pull it toward the back of the unit (similar to Diagram K).
- E. Replace with new Gripper and repeat above steps in reverse order.

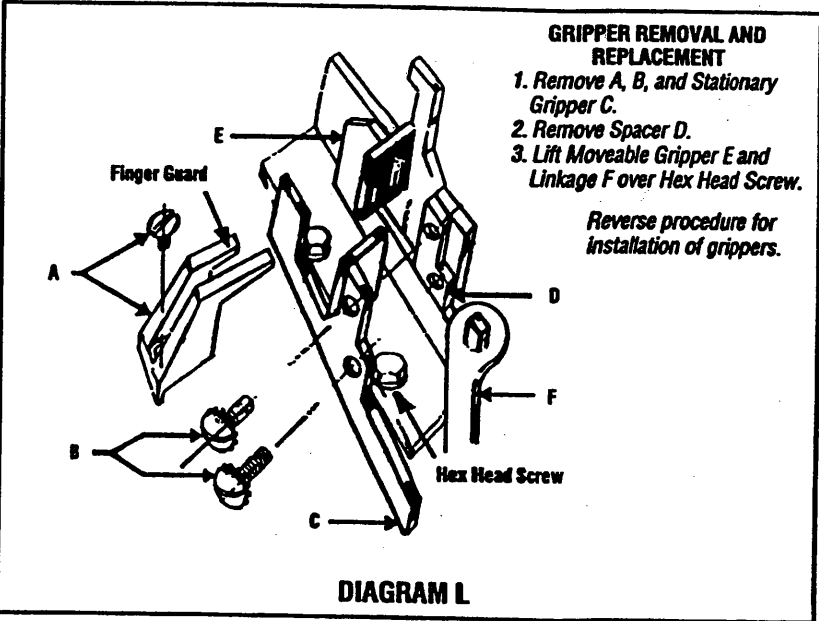

3. SPECIALIZED STRIPPING:
(Hard-to-Strip Insulations)

- A. For hard to strip wires, it will be necessary to use die-type blades.
(See Recommendation below.)
- B. For extremely tough and slippery insulations, it will be necessary to use a "file-type" set of grippers (Part L-8928).

POWER STRIPMASTER BLADE SETS
Knife-Type Blades - For General Purpose Stripping

BLADE #	HOLE DIAMETERS (inches)											mm ² Nom.	HOLE DIAMETERS (mm)																								
	8	10	12	14	16	18	20	22	24	26	28		30	10.00	6.00	4.00	2.50	1.50	1.00	0.50	0.22	0.20	0.13	0.08	0.05												
L-4419	0.159	0.141	0.106												4.04	3.58	2.69																				
L-4420	0.144		0.105	0.085	0.073												3.66	2.67	2.16	1.85	1.85																
L-4421	0.144		0.113	0.09	0.072	0.061	0.048	0.048												3.66	2.87	2.29	1.83	1.55	1.22	1.22											
L-4422	0.09			0.072	0.061	0.039	0.039												2.29		1.83	1.55	0.99	0.99													
L-4452	For SP-SPT																																				
L-4994	0.072			0.061	0.048	0.039	0.032	0.026												1.83	1.55	1.22	0.99	0.813	0.66												
L-5361	0.048			0.039	0.032	0.026	0.021	0.016												1.22	0.99	0.813	0.66	0.533	0.406												
Tolerances: +.001/- .005														Tolerances: +0.25mm/- .127mm																							

NOTE: USE GRIPPER NO. L-5215 WITH ABOVE BLADES

DIE-TYPE AWG BLADES

Diameters = Cutting Hole (inches)
Counterbore (inches)

Blade	AWG	10	12	14	16	18	20	22	24	26	28	30	
For Type E Teflon (800 V)													
L-5559		.119	.096	.076									
L-5560		.136	.113	.0935									
L-5561				.061	.052	.042	.034	.028	.023				
				.081	.070	.0595	.052	.043	.039				
						.023	.019	.016					
						.039	.035	.032					
For Type EE Teflon (1000 V)													
L-5562		.119	.096	.076									
		.144	.125	.104									
L-5563				.061	.052	.042	.034	.028	.023				
L-5564				.089	.0785	.067	.0595	.055	.0465				
						.023	.019	.016					
						.0465	.043	.042					
For PVC & Other Misc. Insulations													
L-5210		.116	.0937	.076									
		.154	.136	.113									
L-5211				.062	.052	.042	.035	.0292	.022				
L-5436				.096	.086	.073	.0635	.0595	.052				
						.024	.020	.016					
						.043	.040	.037					
For Wire Wrap & other thin insulated wire Three identical holes													
L-7625													
L-9300													
								.024	.018	.014	.012		
								.033	.025	.023	.019		
Tolerances: Cutter Dia.: ±.001 C: Bore Dia.: ±.002													

Warning and Safety Instructions

Please read, understand and follow the warnings and instructions in this manual and on the machine. Failure to do so can result in serious personal injury.

- **Do not** operate machine Without the safety guard in place.
 - **Do not** reach inside guards when air supply is connected.
 - **Do not** perform arm maintenance on the machine unless the air supply to the machine is disconnected.
 - **Do not** attempt to replace the blades or the grippers unless the air is disconnected from the machine.
 - **Do not** operate machine without wearing proper eye protection.
 - **Do not** wear base clothing or jewelry that might get caught in the operating parts of the machine.
 - **Do not** alter, modify or misuse the machine.
 - **Do not** operate machine unless all instructions are read and understood.
-

MODEL 45-145

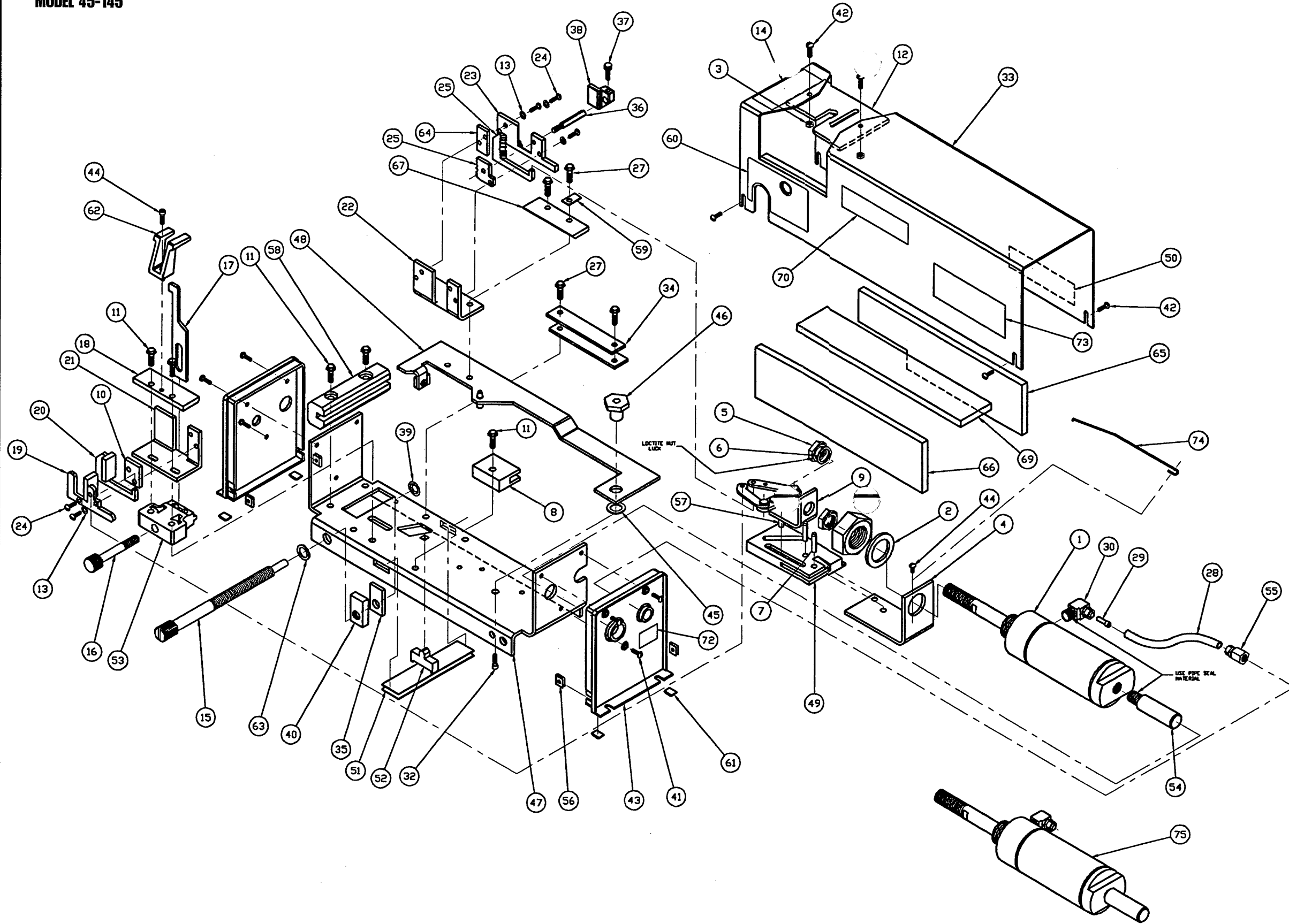

QTY.	REF. NO.	PART NO.	DESCRIPTION
1	1	391.002	CYLINDER
1	2	633.045	LOCKWASHER
2	3	371.052	NUT
1	4	L-9896	CAM HOLDER
2	5	900-887	JAM NUT
1	6	633.020	LOCKWASHER
2	7	281.086	SPRING PIN
1	8	L-9907	SIDE SLIDING BLOCK
1	9	K-4963	LINKAGE ASSEMBLY
1	10	L-9766	GRIPPER SPACER
5	11	506.002	SCREW
1	12	LA-3223	GUARD
5	13	901-850	LOCKWASHER
1	14	LA-2489	LABEL (GUARD)
1	15	L-9903	WIRE GUIDE SCREW
1	16	L-9899	STRIP ADJ. SCREW
1	17	K-4969	WIRE GUIDE
1	18	L-9894	SPACER
1	19	L-5217	STATIONARY GRIPPER
1	20	L-5212	MOVEABLE GRIPPER
1	21	K-4966	GRIPPER HOLDER
1	22	K-4965	BLADE HOLDER
1	23	K-4967	BLADE GUIDE PLATE
5	24	900-282	SCREW
1	25	L-4421	BLADE PAIR
26	26		
4	27	506.003	SCREW
7	28	543.031	PLASTIC TUBING
1	29	L-9906	AIR MOTION RESTRICTOR
1	30	263.006	MALE ELBOW FITTING
1	31	1202.048	SEALING COMPOUND
1	32	900-114	SCREW
1	33	H-10871	COVER ASSEMBLY
2	34	L-9895	CAM SLIDING STRIP
1	35	L-9960	SHOCK ABSORBER
1	36	L-5152	STOP ROD
1	37	352.007	SCREW
1	38	L-9324	WIRE STOP
1	39	378.008	PUSH NUT
1	40	L-9902	STRIP ADJ. BLOCK
6	41	358.015	SCREW
6	42	358.010	SCREW
2	43	I-2784	END PANEL
2	44	900-107	SCREW
1	45	632.113	WASHER
1	46	L-9901	PIVOT NUT
1	47	H-8091	BASE PLATE
1	48	K-4972	ARM ASSEMBLY
1	49	I-2785	CAM
1	50	LA-3224	LABEL (LUBRICATION)
2	51	L-9904	LEAF SPRING
1	52	L-9900	FRICTION BUTTON
1	53	I-2783	WIRE GUIDE HOLDER
1	54	L-9897	SLIDING ROD
1	55	263.007	FEMALE CONNECTOR
4	56	378.007	SPEED NUT
1	57	281.083	SPRING PIN
1	58	K-4964	FRONT SLIDING BLOCK
1	59	L-9938	RETAINER
1	60	L-9908	LABEL (INSTRUCTION)
4	61	081.006	BUMPERS
1	62	I-2786	SAFETY GUARD
1	63	L-9915	WASHER, URETHANE
1	64	L-9917	BLADE SPACER
1	65	K-4975	SOUND ABSORBER (CUT)
1	66	K-4974	SOUND ABSORBER
1	67	L-9956	SPACER
68	68		
1	69	K-4997	SOUND ASORBER
1	70	LA-3225	LABEL (CAUTION)
71	71		
1	72	915-684	LABEL (CE)
1	73	140678	NAMEPLATE
1	74	L-9470	SLUG EJECTOR
REF	75	L-9968	AIR CYLINDER KIT

H-1086i	HEAT TREATMENT/SURFACE TREATMENT	MATERIAL DESCRIPTION	USED FOR	CLASS CODE
	CONFIDENTIAL	D	45-145	130
				REVISION DATE
	POWER STRIPMASTER			12/20/01
WORK TO MEAN DIMENSIONS DO NOT SCALE DRAWING		SCALE 1:2	REVISION	A
DRAWN BY: NORMMH CHECKED BY: H. KEENE		DATE: 10/04/2001	SHEET NUMBER	1 of 1